

COMBINATION LADDER & PLATFORM

Assembly Instructions

Read instructions fully before assembly

COMPONENTS LIST

Check components before commencing assembly. If components are missing or damaged please contact 01773 525730. Do not use the product unless assembly has been completed.

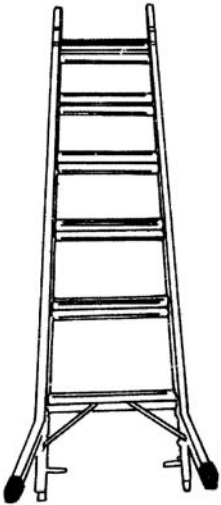

Ladder

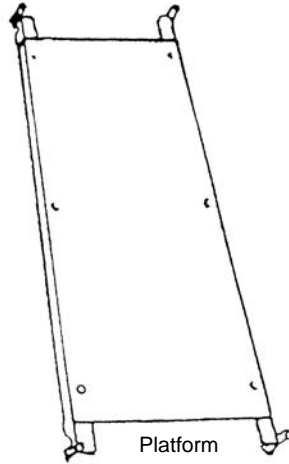

Platform



Latched Hook
Left x 2



Latched Hook
Right x 2



M6 x 70mm bolt
x 4



M6 x lock nut
x 4



6mm Ø Washer
(metal) x 4



M8 25mm bolt
x 4



8mm Ø Washer
(metal) x 4



8mm Ø Washer
(nylon) x 4



M8 lock nut
x 4



Stabiliser Bar

LADDER ASSEMBLY

Attach Stabiliser

1. Remove plastic tips from base of ladder section and set aside. (figure 1)
2. Offer stabiliser up to slots in stile and align 4 holes. Fix in place with four M6 x 70mm bolts, four 6mm Ø metal washers and four M6 lock nuts (fig. 2) Do not overtighten. Replace plastic tips. (fig. 3)

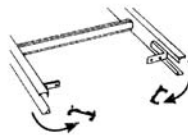

figure 1

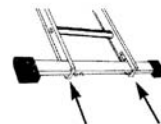

figure 2

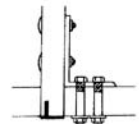

figure 3

PLATFORM ASSEMBLY

Attach Latched Hooks

1. Locate right and left latched hooks and offer up to platform rails. Align with round holes and fix in place with two M8 x 25mm bolts, two 8mm Ø Nylon Washers, two 8mm Ø metal washers and two M8 lock nuts as per illustration.

Note: The **nylon** washers must be positioned between the strut and the outside face of the platform rails.

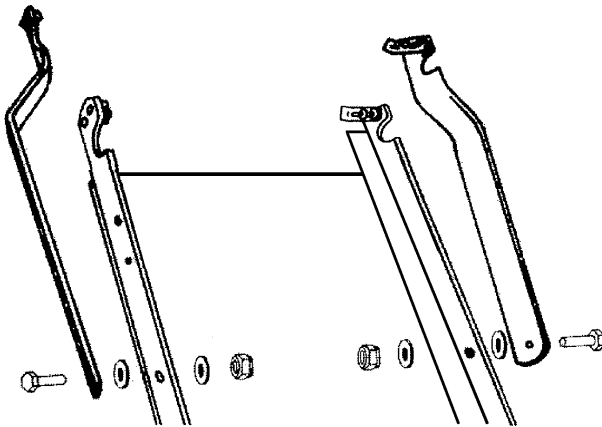

2. Repeat above at other end of platform.
3. Tighten sufficiently to allow the hooks to rotate.

IMPORTANT

Before use check that all assembly operations have been completed correctly. Read operation instructions on product fully and practice setting both ladder and platform modes. Failure to do so may result in an accident.